

14 0.89 [.035] REF
 INTERRUPTED WALL FOR POSITION SIZES 6 AND ABOVE

- 1 MATERIAL
HOUSING: THERMOPLASTIC POLYESTER, GLASS FILLED, DR-48. UL94V-O.
POST: COPPER ALLOY
- 2 FINISH
HOUSING: BLACK
POST: BRIGHT TIN-LEAD (93/7) 0.00380 [.000150]-0.00880 [.000350] THICK OVER NICKEL UNDERPLATE 0.00130 [.000050] MINIMUM THICK OR MATTE TIN PLATE 0.00380 [.000150] THICK OVER NICKEL UNDERPLATE 0.00130 [.000050] MINIMUM THICK IF LEAD FREE.
- 3 UL MARKING MAY NOT APPEAR ON THE 3 POSITION SIZE.
- 4 POST SOLDERTAILS COMPLY WITH AMP SOLDERABILITY SPEC 109-11-2.
- 5 POST WITHSTANDS 13.34N (3 LB) MIN AXIAL FORCE IN EITHER DIRECTION WITHOUT DISLODGING.
- 6 APPLIES AT -A-.
- 7 APPLIES WHEN THE HEADER IS STRAIGHT.
- 8 PLASTIC PROJECTIONS PERMITTED IN THIS ZONE.
- 9 COORDINATE DIMENSIONS APPLIES FROM THE CENTER OF THE ACTUAL FEATURE.
- 10 SOLDER SIDE OF BOARD IS SHOWN.
- 11 DIMENSIONS IN BRACKETS ARE IN INCHES.
- 12 ALL POSITION SIZES HAVE THE BACK WALL NOTCHED ON BOTH ENDS AS SHOWN. THE 2 THRU 5 POSITION SIZES HAVE SOLID BACK WALLS. POSITION SIZES 6 AND ABOVE HAVE AN INTERRUPTED BACK WALL AT VARIOUS LOCATIONS (SEE TABLE FOR INTERRUPTION(S) LOCATIONS).
- 13 EDGE OF POLARIZING LOCK WALL TO BE IN LINE WITH CENTERLINE OF ADJACENT POST WITHIN ±0.13 [.005]
- 14 NOTCH SHOWN MAY OR MAY NOT APPEAR.

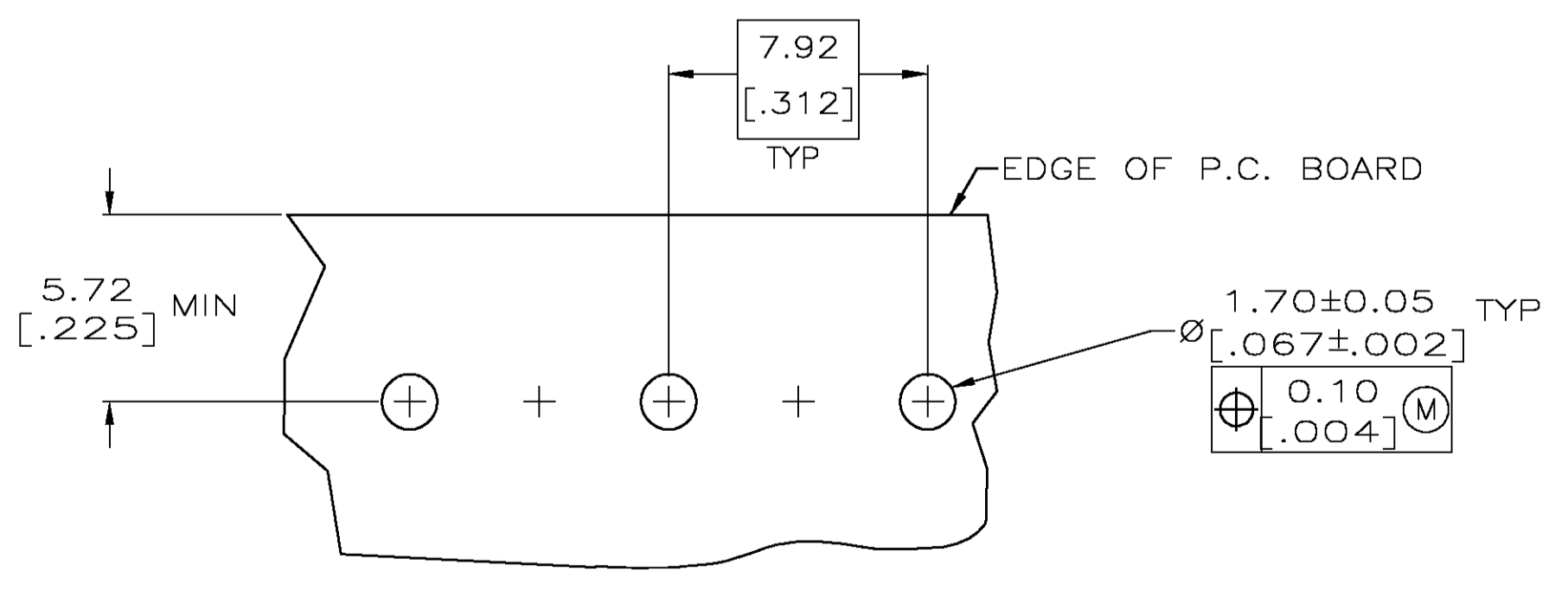

RECOMMENDED MOUNTING HOLE PATTERN FOR 1.57 [.062] THICK P.C. BOARD

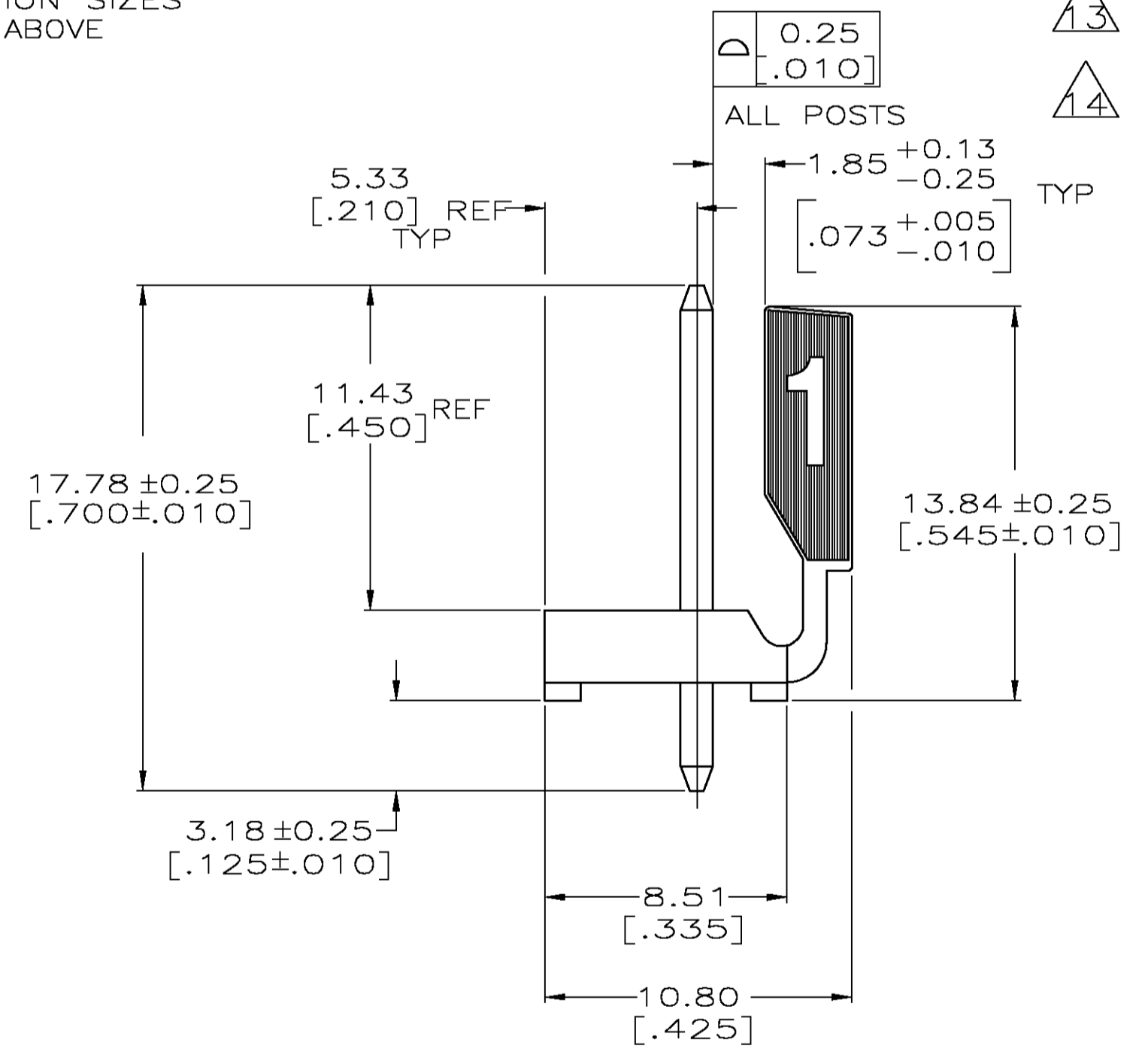
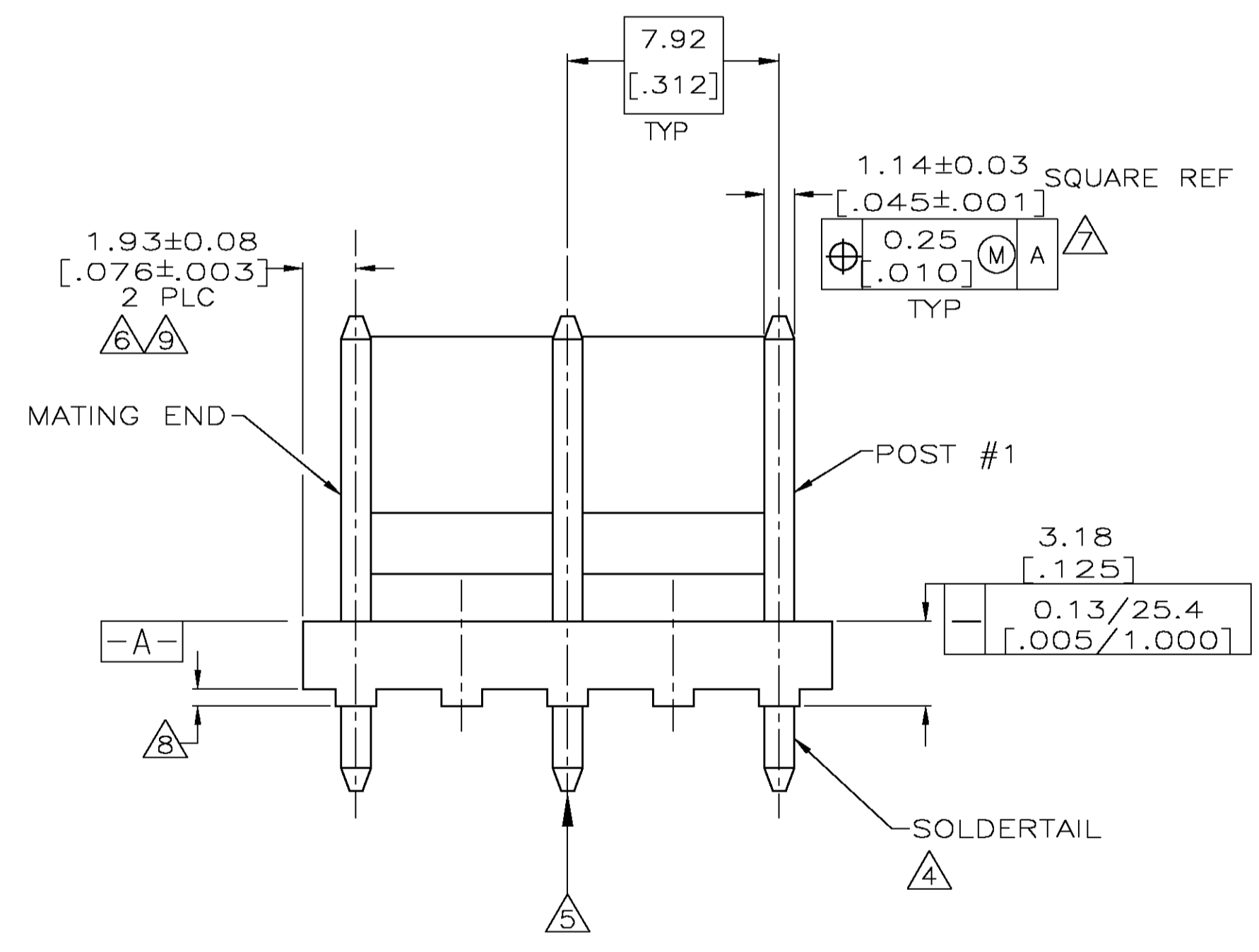

YES	NONE	19.69	[.775]	5	3-647182-5
NO	NONE	19.69	[.775]	5	647182-5
LEAD FREE	BACK WALL INTERRUPTIONS BETWEEN POSTS	mm	[IN]	NO OF POSITIONS	PART NUMBER

THIS DRAWING IS A CONTROLLED DOCUMENT.		DN S. HOOVER 22-OCT-2004	Tyco Electronics Corporation Harrisburg, Pa 17105-3608
DIMENSIONS: mm [INCHES]		CHK D. BOSSI 22-OCT-2004	
TOLERANCES UNLESS OTHERWISE SPECIFIED:		APPD D. BOSSI 22-OCT-2004	NAME ASSEMBLY- MTA .156 HEADER, POLARIZED LOCK, STR .045 SQUARE POST, TIN OR TIN-LEAD PLATED, OMITTED POST #2 & 4, SPECIAL
0 PLC ±		PRODUCT SPEC	
1 PLC ±		APPLICATION SPEC	SIZE
2 PLC ±		WEIGHT	CAGE CODE
3 PLC ± 0.13 [.005]		CUSTOMER DRAWING	DRAWING NO
4 PLC ±		SCALE 5:1	SHEET 1 OF 1
ANGLES ±			REV D
FINISH			